

BB20 z 1 do 6 sekcji

BB20 from 1 to 6 levers

Charakterystyki ogólne / Technical characteristics		
	l/min GPM	
• Wydatek nominalny / Nominal flow	17	4,5
• Wydatek maksymalny / Max flow	25	6,6
	bar PSI	
• Ciśnienie nominalne / Nominal pressure	250	3600
• Ciśnienie max na odbiornikach / Max pressure on ports	320	4700
• Max ciśnienie na powrocie / Max pressure in tank-line	80	1100

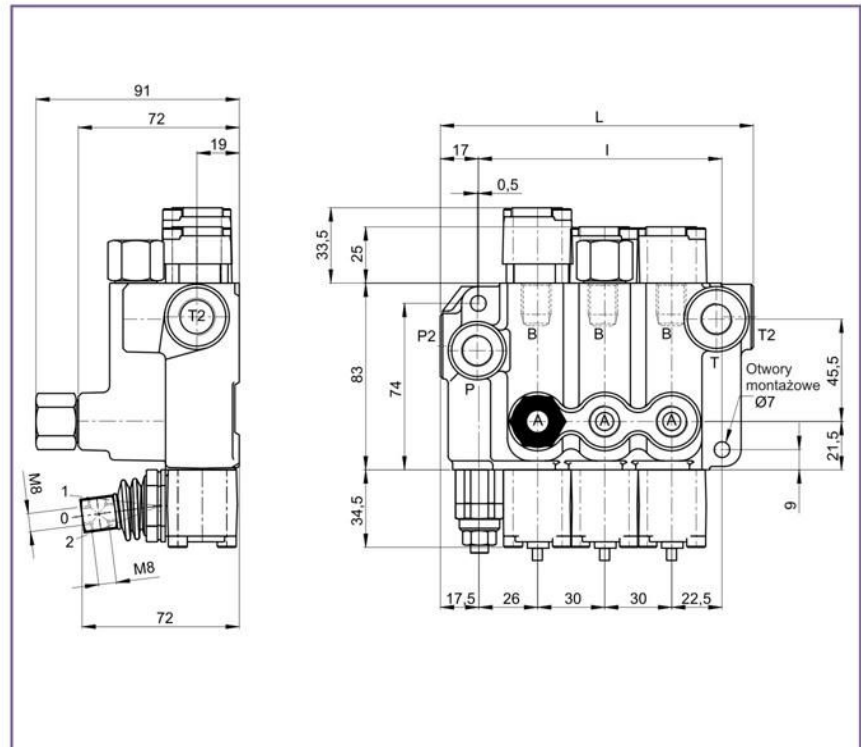
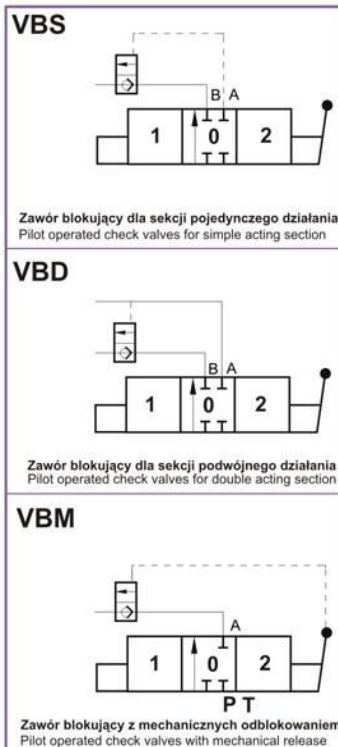
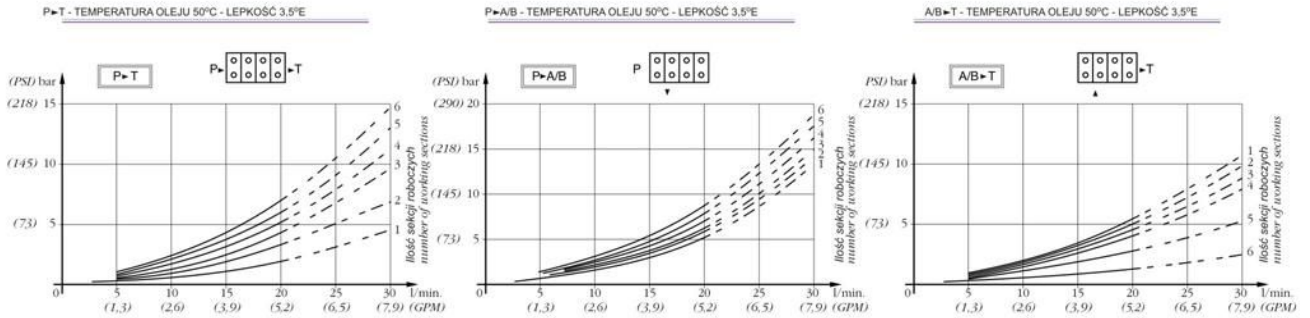

MOD	L	I	Kg
BB20/1*	76	50	1,8
BB20/2	106	80	2,9
BB20/3	136	110	4
BB20/4*	166	140	5
BB20/5*	196	170	6,1
BB20/6	226	200	7,2

GWINTY STANDARDOWE - STANDARD THREAD					
COD	A-B	P	T	P ₂	T ₂
G	1/4"	1/4"	3/8"	3/8"	3/8"
F	9/16" - 18	9/16" - 18	9/16" - 18	3/4" - 16	3/4" - 16

◀ Na żądanie jest dostępny inny gwint
Other thread available on request

